

PowerFlushPro

The PowerFlush Pro is a fully automatic macerator suitable for pumping waste from a complete bathroom to a higher level when gravity drainage is not possible and/or economical to install. The system can accept waste connections from a toilet, basin, shower or bidet.

It is not suitable for connection to washing machine, dishwasher or bath.

The system features razor sharp stainless steel blades that act like a pair of rotary scissors to cut up waste items, reducing the chance of a blockage.

It includes a BMS-compatible high level alarm

The system is compact and easy to install. It discharges to the right or left. The 100mm inlet to the chamber can be fitted centrally on the front face or side.

KEY FEATURES

- Inlet and discharge pipe work can be fitted to either side of the unit for maximum versatility
- Designed to accept waste from a full bathroom suite including toilet, basin, shower and bidet
- Supplied as standard with a BMS compatible high level alarm

WASTE TYPE



Grey

Foul



INSTALLATION EXAMPLES

Behind toilet

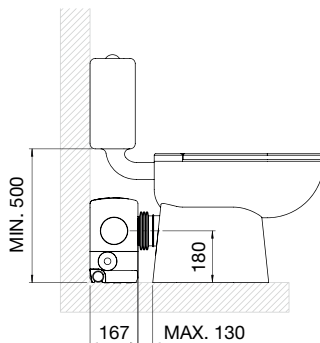

Behind partition with wash basin connection

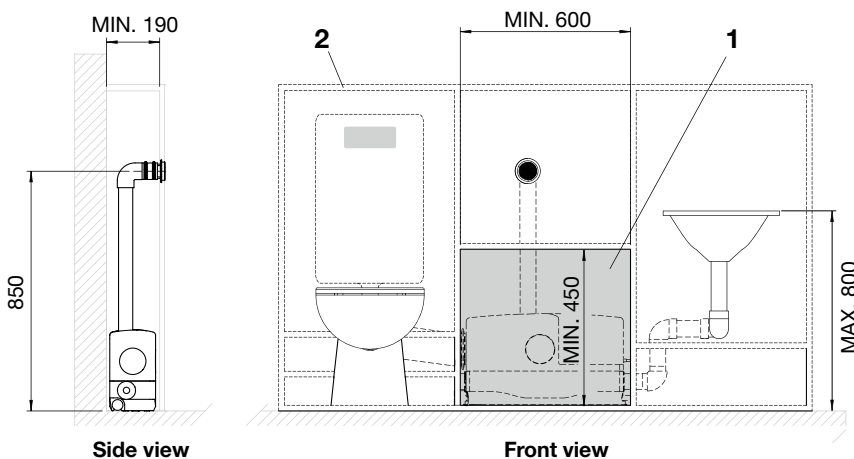

TECHNICAL DATA

Operating parameters

Power supply	230V 50Hz
Rated current	4.6 A
Motor rating	1000 W
Revolutions per min.	2900rpm
Max vertical output	10 m
Max flow rate	2 l/s
Max liquid temp.	<60°C intermittent
Discharge size	32 mm
Cable length	1.8 m
Weight	7 kg
Colour	White

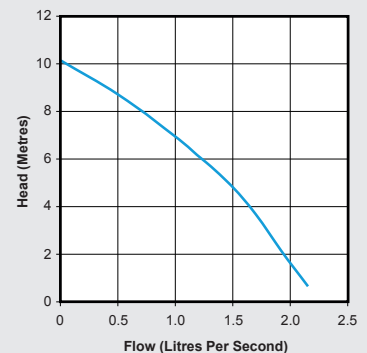

Connections

Side discharge line with integral check valve	To the right or left. 32 mm OD / 25 mm OD
Side inlets	1 x DN 50 (right) 1 x DN 50 (left)
Toilet connection (optional connections)	1 x DN 100 (front) 1 x DN 100 (side)
Vent line	DN 50 vent with carbon filter

PowerFlushPro

DIMENSIONS (mm)

Front toilet connection

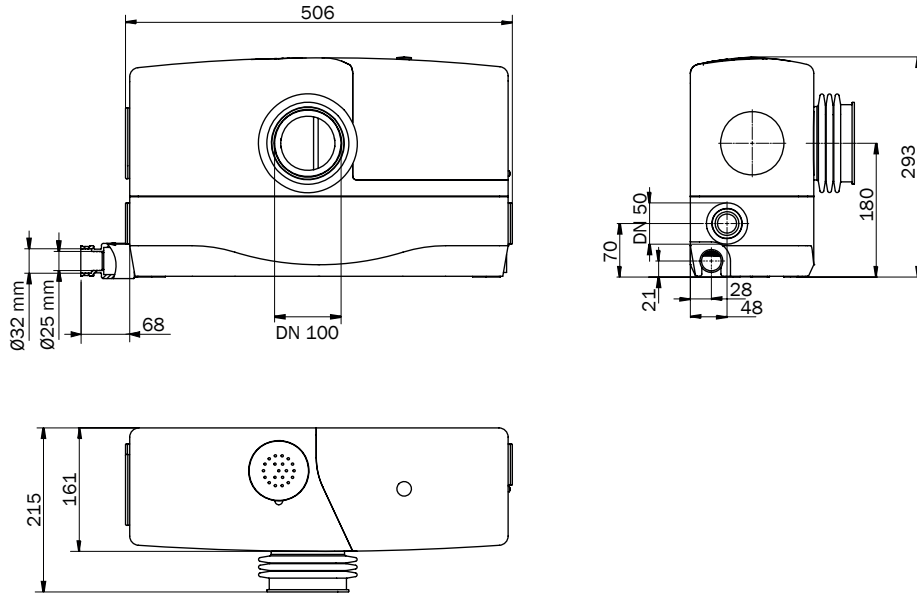

Side toilet connection

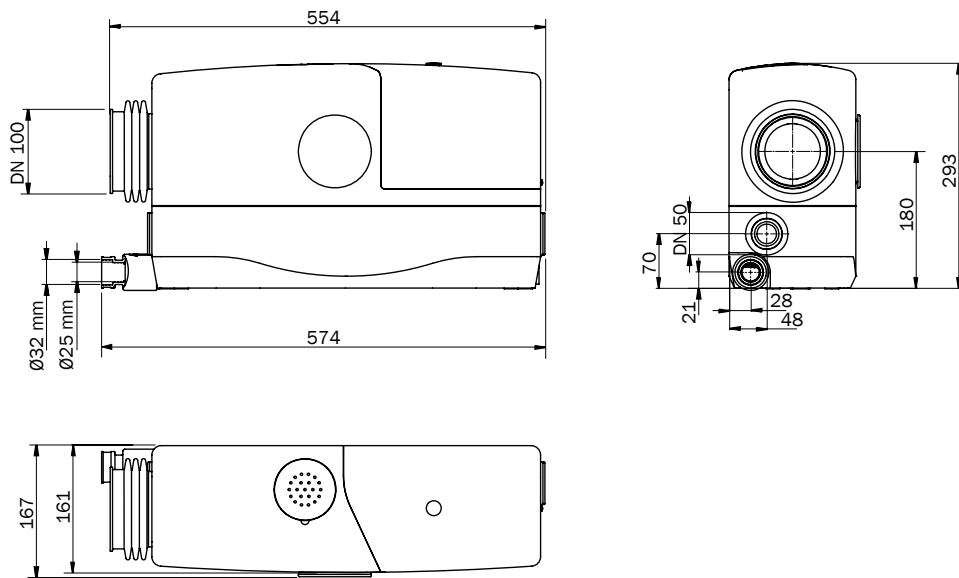

DELIVERING PUMPED AND DRAINAGE SOLUTIONS FOR OVER 25 YEARS

- Packaged pumping stations
- Waste water pumping systems
- Macerators and macerating toilets
- Floor mounted pumping stations
- Fat, oil and grease separating systems
- Rainwater harvesting systems
- Battery backup systems
- Adoptable pumping stations
- Submersible pumps
- Accessories



We provide pumped and drainage products and services to the public and private sectors, including residential, commercial, hospitality and retail.

We are proud of the long-term relationships we have built with our clients and partners, delivering cost effective, robust and dependable products and services.

12-MONTH GUARANTEE

Your products are protected by a 12-month guarantee. Please refer to our Terms and Conditions at www.edincare.com

HOW TO ORDER

Order online at www.edincare.com
 Call Sales on 01442 211554
 Email sales@edincare.com

PROJECT SERVICES

- Project design
- Site surveys
- Installations
- Refurbishments

AFTERSALES SERVICES

- Planned servicing
- Emergency call outs
- Commissioning
- Monitoring

DRAINAGE SERVICES

- Tankering
- Jetting
- Drainage CCTV
- Surveys
- Cleaning and de-scaling
- Structural repairs
- Excavations
- Root cutting

www.edincare.com

- Discover our products and services
- Order products online
- Case studies and articles
- Brochures and technical documents

Protect your property with an Edincare Service Agreement

As with all pumped and drainage systems, regular maintenance is essential to ensure optimum performance and minimal downtime. Our Service Agreements comprises planned preventive maintenance visits at an agreed frequency, we also service other manufacturers' equipment regardless of type, make and age.

- ✓ Validates your building insurance
- ✓ Reduces the risk of failure
- ✓ Increases the life expectancy of your equipment
- ✓ Priority callouts and 24/7 out-of-hours service
- ✓ Reduced rates for emergency call outs
- ✓ Flexible payment options (Direct Debit)



+44 (0)1442 211554
info@edincare.com

www.edincare.com
 edincarepumps

Unit 8, Heron Business Park, Eastman Way,
 Hemel Hempstead, Hertfordshire, HP2 7FW

Part of the Edincare Group of Companies www.edincaregroup.com



Our policy is one of continuous product improvement, we reserve the right to change specifications and prices without prior notice. All information is given in good faith. No responsibility can be accepted for errors, omissions or incorrect assumptions. © Omni Pump International Ltd t/a Edincare Pumps & Edincare Drains. All rights reserved.