

EcoTrap 1150 below-ground grease trap

The EcoTrap 1150 is a fat, oil and grease separator suitable for installing below ground.

Its distinctive profile provides excellent grease and solid retention. It is manufactured from high-density polyethylene (HDPE) in a one-piece moulding technique which ensures exceptional strength and durability.

The EcoTrap 1150 features 110 mm pipework connections and 3.5 tonne rated lockable plastic 450mm circular covers. A 220 mm circular chamber extension riser is available if needed.



DIMENSIONS (mm)

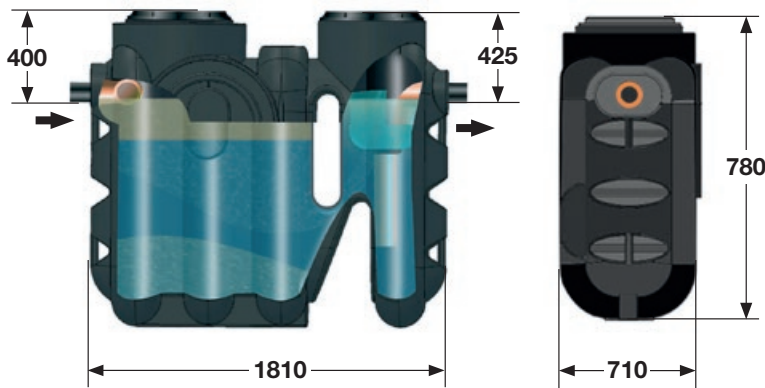

KEY FEATURES

- Suitable for large hotels and food processing plants
- Prevents fat, oil and grease entering the drainage system
- Environmentally-friendly
- Easy to install and maintain
- High density polyethylene chamber
- Use in conjunction with BioFax enzyme
- Suitable for below ground installation
- Lockable plastic cover
- Conforms with BS EN1825 and UK Building Regulations Part H

TECHNICAL SPECIFICATIONS

Inlet	110 mm
Outlet	110 mm
Material	HDPE
Capacity	1150 litres

ACCESSORIES

<p>EcoTrap neck extension (220 mm)</p> <p>#5050</p>	<p>Dosing pump (Mains Operated)</p> <p>#11000</p>	<p>Dosing pump (Battery Operated)</p> <p>#11068</p>	<p>BioFax, 10 litres, double concentrated</p> <p>#28004</p>
--	--	--	--

WASTE



All our products can be customised to your requirements. For more information and advice please call 01442 211554.

DELIVERING PUMPED AND DRAINAGE SOLUTIONS FOR OVER 25 YEARS

Packaged pumping stations

Waste water pumping systems

Macerators and macerating toilets

Floor mounted pumping stations

Fat, oil and grease separating systems

Rainwater harvesting systems

Battery backup systems

Adoptable pumping stations

Submersible pumps

Accessories



We provide pumped and drainage products and services to the public and private sectors, including residential, commercial, hospitality and retail.

We are proud of the long-term relationships we have built with our clients and partners, delivering cost effective, robust and dependable products and services.

12-MONTH GUARANTEE

Your products are protected by a 12-month guarantee. Please refer to our Terms and Conditions at www.edincare.com

HOW TO ORDER

Order online at www.edincare.com
Call Sales on 01442 211554
Email sales@edincare.com

PROJECT SERVICES

- Project design
- Site surveys
- Installations
- Refurbishments

AFTERSALES SERVICES

- Planned servicing
- Emergency call outs
- Commissioning
- Monitoring

DRAINAGE SERVICES

- Tankering
- Jetting
- Drainage CCTV
- Surveys
- Cleaning and de-scaling
- Structural repairs
- Excavations
- Root cutting

www.edincare.com

- Discover our products and services
- Order products online
- Case studies and articles
- Brochures and technical documents

Protect your property with an Edincare Service Agreement

As with all pumped and drainage systems, regular maintenance is essential to ensure optimum performance and minimal downtime. Our Service Agreements comprises planned preventive maintenance visits at an agreed frequency, we also service other manufacturers' equipment regardless of type, make and age.

- ✓ Validates your building insurance
- ✓ Reduces the risk of failure
- ✓ Increases the life expectancy of your equipment
- ✓ Priority callouts and 24/7 out-of-hours service
- ✓ Reduced rates for emergency call outs
- ✓ Flexible payment options (Direct Debit)



+44 (0)1442 211554
info@edincare.com

www.edincare.com
edincarepumps

Unit 8, Heron Business Park, Eastman Way,
Hemel Hempstead, Hertfordshire, HP2 7FW

Part of the Edincare Group of Companies www.edincaregroup.com



Our policy is one of continuous product improvement, we reserve the right to change specifications and prices without prior notice. All information is given in good faith. No responsibility can be accepted for errors, omissions or incorrect assumptions. © Omni Pump International Ltd t/a Edincare Pumps & Edincare Drains. All rights reserved.